

Piston Pumps (Mobile or Industrial)



P1/PD Medium Pressure Piston Pumps



P1



PD

- Variable displacement, axial piston pump for open-circuit applications
- Medium pressure, continuous operation at pressures up to 4060 PSI (280 BAR)
- Compact, quiet and efficient control
- Wide temperature range suitable for mobile applications

P1 Mobile Pump Performance Data

Model Series	Displacement in ³ /rev (cc/rev)	Max. Outlet Pressure PSI (BAR)	Rated Drive Speed RPM	Flow GPM (LPM)	Input Horsepower HP (KW)
P1018	1.10 (18)	4000 (280)	3200	15 (56.8)	44 (32.8)
P1028	1.71 (28)	4000 (280)	3200	24 (90.8)	70 (52.2)
P1045	2.75 (45)	4000 (280)	2600	31 (117.3)	90 (67.1)
P1060	3.66 (60)	4000 (280)	2500	37 (140.1)	117 (87.2)
P1075	4.58 (75)	4000 (280)	2300	42 (159.0)	127 (94.7)
P1100	6.10 (100)	4000 (280)	2100	54 (204.4)	155 (115.6)
P1140	8.54 (140)	4000 (280)	2000	71 (268.8)	206 (153.6)

Markets

Applications

Forestry	Feller Bunchers, Knuckle Boom Loader, Skidder, Forwarder, Cranes
Oil & Gas	Nitrogen Pumps, Cementers, Coil Tubing
Construction	ADTs, Fan Drives
Mining	Drill Rigs, Top Drives, Loaders, Dump Trucks, Tunneling Equipment
Power Gen	Lube Oil Skids
Recycling	Shredders, Balers, Compactors, Vacuum Truck Systems, Refuse Trucks - ASL, Rear Loaders
Military	Fan Drives
Utility	Cranes, Digger Derricks, Man Lifts, Cable Placers, Fan Drives, Horizontal Directional Drills

PD Industrial Pump Performance Data

Model Series	Displacement in ³ /rev (cc/rev)	Max. Outlet Pressure PSI (BAR)	Rated Drive Speed RPM	Flow GPM (LPM)	Input Horsepower HP (KW)
PD018	1.10 (18)	4000 (280)	1800	8 (30.3)	23 (17.2)
PD028	1.71 (28)	4000 (280)	1800	13 (49.2)	33 (24.6)
PD045	2.75 (45)	4000 (280)	1800	21 (79.5)	53 (39.5)
PD060	3.66 (60)	4000 (280)	1800	27 (102.2)	79 (58.9)
PD075	4.58 (75)	4000 (280)	1800	34 (128.7)	100 (74.6)
PD100	6.10 (100)	4000 (280)	1800	46 (174.1)	133 (99.2)
PD140	8.54 (140)	4000 (280)	1800	63 (238.5)	185 (138.0)

Markets

Applications

Industrial	Power Units, Industrial Molding, Press
Oil & Gas	Oil Lift Pumps
Power Gen	Turbine Start
Material Handling	Conveyor Drives



Piston Pumps (Mobile or Industrial)

P1/PD Medium Pressure Mobile Piston Pumps



P1/PD

Benefits/Features

- Compact overall package size
- Quiet operation
- Low flow ripple to further reduce noise
- Elastomer seals that eliminate gaskets and external leakage
- High operating efficiency for lower power consumption and reduced heat generation
- Simple hydraulic controls with “no-leak” adjustments
- SAE and ISO standard mounting flanges and ports
- Long life, tapered-roller shaft bearings
- Long life, low friction, hydrostatically balanced cam bearings
- Full power through-drive capability
- End or side inlet and outlet ports
- Case drain ports for horizontal or vertical, shaft-up mounting
- Optional minimum and maximum displacement adjustments
- Optional case-to-inlet check valve to extend shaft seal life
- Easy to service

P1 Medium Pressure Mobile Piston Pumps

Performance Characteristics

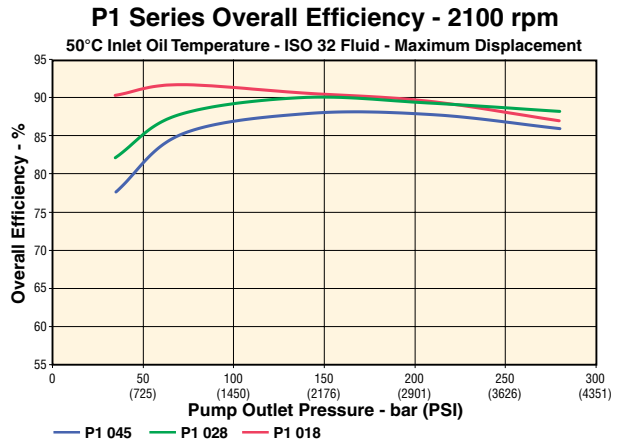
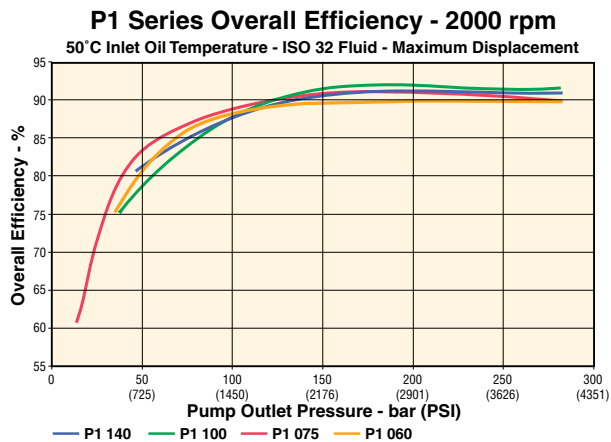
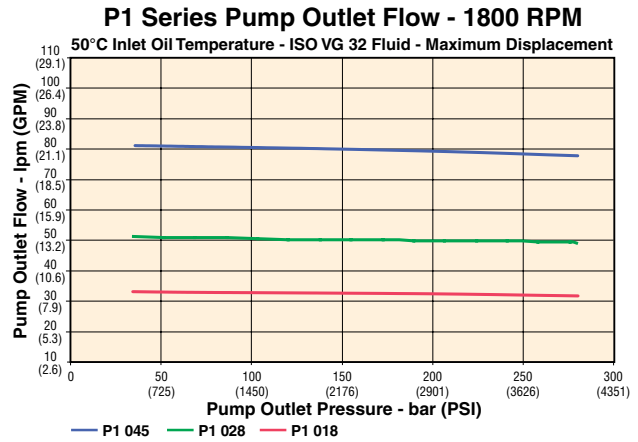
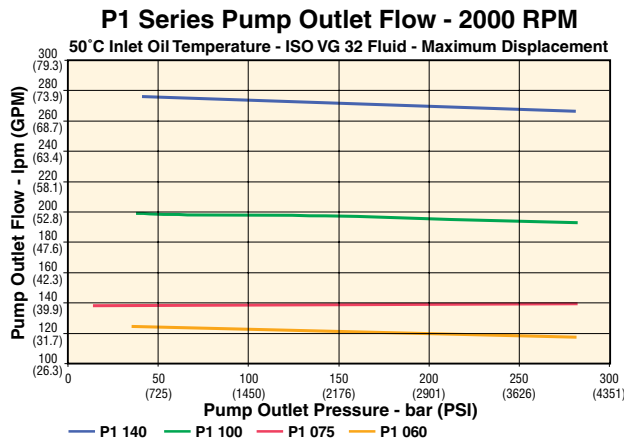
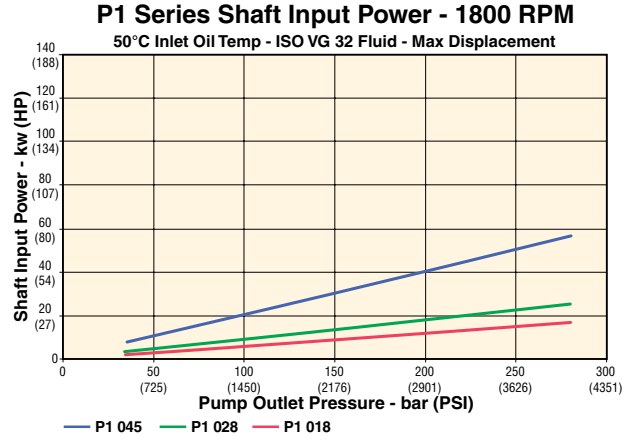
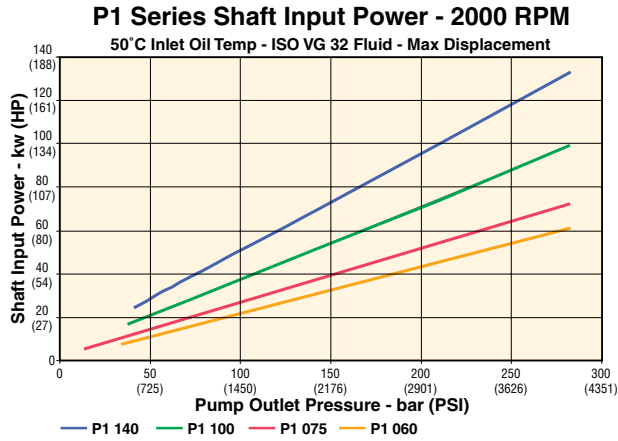



Piston Pumps (Industrial)

PD Medium Pressure Industrial Piston Pumps

Performance Characteristics

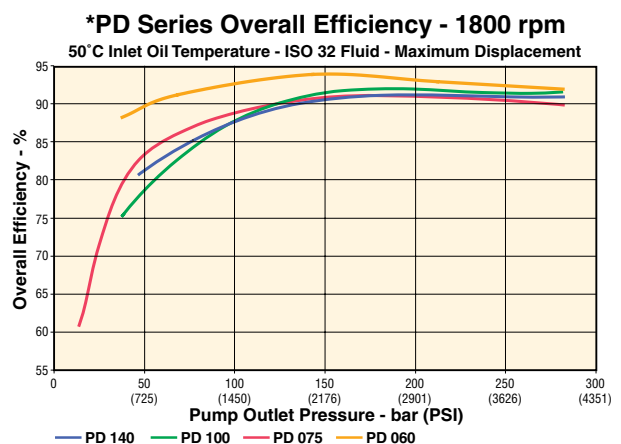
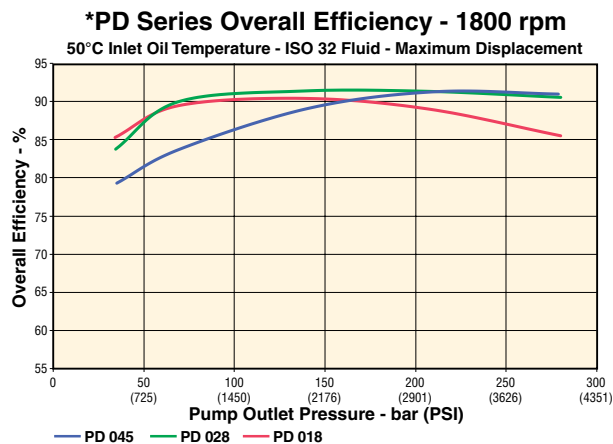
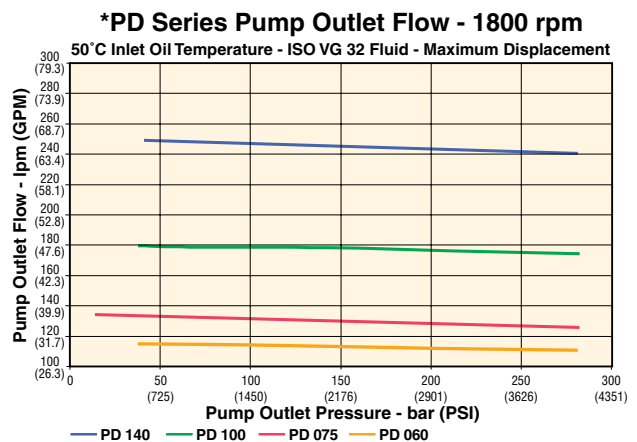
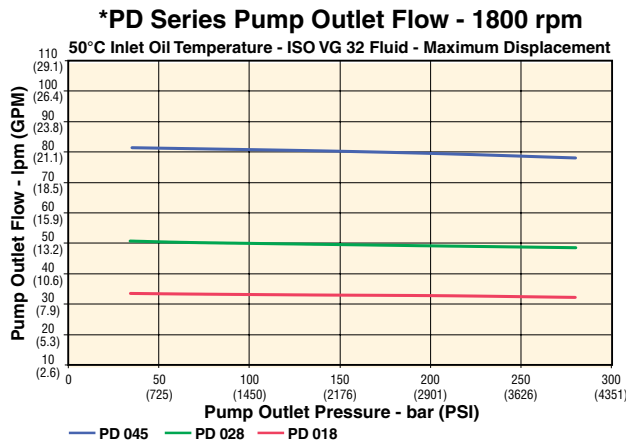
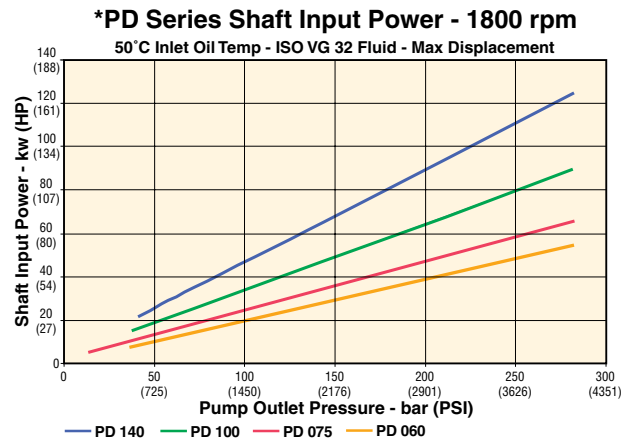
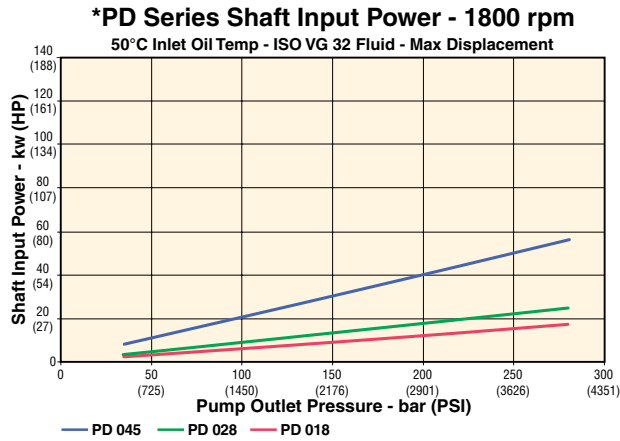

* For additional speeds, see enclosed CD

P1/PD Medium Pressure Mobile Piston Pumps

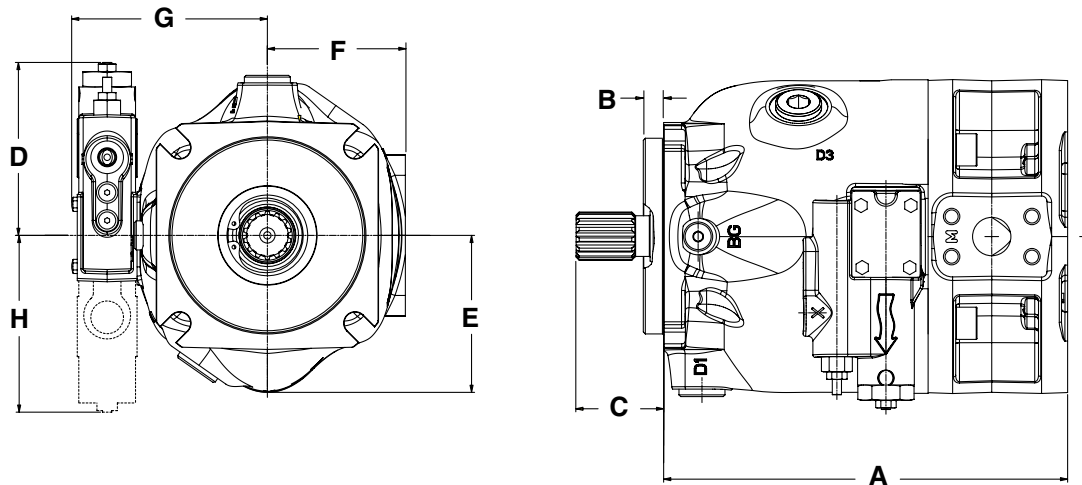

Dimensions, inch (mm)

Series	A	B	C Max.	D	E	F	G	H Max.
P1/PD018	6.46 (164.2)	0.24 (6.2)	1.29 (32.8)	4.72 (120)	2.97 (75.5)	2.60 (66)	4.24 (107.7)	4.80 (122)
P1/PD028	9.25 (235.5)	0.37 (9.5)	1.84 (46.8)	4.72 (120)	3.21 (81.5)	2.93 (74.5)	4.48 (113.8)	4.80 (122)
P1/PD045	9.00 (228.7)	0.37 (9.5)	1.84 (46.8)	4.72 (120)	3.63 (92.3)	2.92 (74.2)	4.75 (120.7)	4.80 (122)
P1/PD060	9.96 (253.0)	0.50 (12.7)	2.24 (56.8)	4.72 (120)	3.98 (101.2)	3.23 (82)	4.88 (123.9)	4.80 (122)
P1/PD075	10.37 (263.5)	0.50 (12.7)	2.24 (56.8)	4.72 (120)	4.09 (103.8)	3.54 (90)	5.03 (127.7)	4.80 (122)
P1/PD100	13.37 (339.6)	0.50 (12.7)	2.47 (62.8)	4.72 (120)	4.61 (117.1)	3.98 (101)	5.66 (143.7)	4.80 (122)
P1/PD140	14.34 (364.3)	0.50 (12.7)	2.97 (75.5)	4.72 (120)	5.24 (133)	4.45 (113)	6.13 (155.7)	4.80 (122)

SAE Flanges & Shafts

	PD018	PD028, PD045	PD060, PD075	PD100	PD140
Mounting flange, SAE	82-2 (A)	101-2 (B)	127-4 (C)	127-4 (C)	152-4 (D)
Pilot diameter, in (mm)	3.2 (82.5)	4.0 (101.6)	5.0 (127)	5.0 (127)	6.0 (152.4)
Keyed shaft, SAE	19-1 (A)	25-1 (B-B)	32-1 (C)	38-1 (C-C)	44-1 (D)
Spline shaft, SAE	11T-16/32P	15T-16/32P (B-B)	14T-12/24P (C)	17T-12/24P (C-C)	13T-8/16P (D)



Piston Pumps

P1/PD 18cc, Model Ordering Code

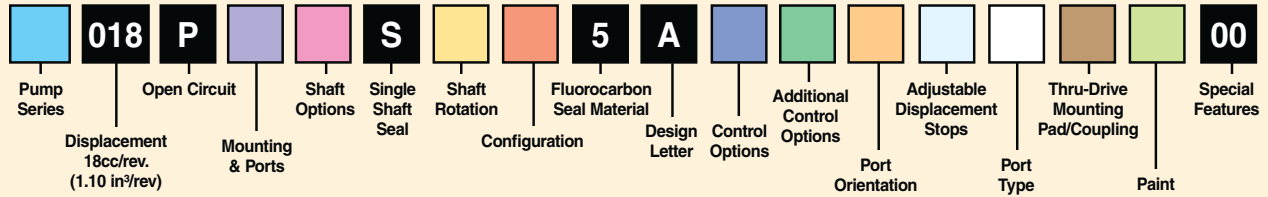

Pump Series	
P1	Mobile
PD	Industrial

Mounting & Ports	
S	SAE A Pilot SAE Threaded Work Ports with SAE Aux Ports
A	SAE A Pilot Metric Work Ports with BSPP Aux Ports
M	ISO - 80mm Pilot Metric Work Ports with Metric Aux Ports
B	ISO - 80mm Pilot Metric Work Ports with BSPP Aux Ports

Shaft Options	
01	Splined shaft - SAE 19-4 11T
02	Keyed shaft - SAE 19-1 .75" Dia.
04	ISO keyed 20MM Dia.
06	Splined shaft - SAE A 9T*

*Not available with Thru-Drive

Shaft Rotation	
R	Clockwise
L	Counterclockwise

Configuration	
M	Mobile (P1)
S	Industrial (PD)

Control Options	
C0	Pressure limiter 1160.30 - 4061.05 PSI (80 - 280 bar)
C1	Pressure limiter 290.08 - 1160.30 PSI (20 - 80 bar)
L0	Load sensing 145.04-435.11 PSI ΔP (10-30 bar ΔP) with pressure limiter 1160.30 - 4061.05 PSI (80 - 280 bar)
L2	Load sensing 145.04-435.11 PSI ΔP (10-30 bar ΔP) with bleed & pressure limiter 1160.30 - 4061.05 PSI (80 - 280 bar)
AN*	Pilot operated pressure limiter with ISO4401 interface & SAE 4 Vent Port
AM	Pilot operated pressure limiter with mechanical adjustment and SAE 4 Vent Port
AE	Pilot operated pressure limiter with mechanical and electrical adjustment 12 VDC
AF	Pilot operated pressure limiter with mechanical and electrical adjustment 24 VDC
##	See chart below for electronic control options

*Not functional control as such

Additional Control Options	
0	No other options
2	Displacement sensor **

** mandatory with "W***", "X***", "Y***", "Z***" "D*" and "Y*"

Port Orientation	
E	End Ports
R	Side ported with ripple chamber
T	Side ported with Thru-Drive

Adjustable Displacement Stops	
0	None
1	Adjustable maximum displacement stop
2	Adjustable minimum displacement stop
3	Adjustable maximum and minimum displacement stop

Port Type	
0	Flange Ports*
2	Threaded Ports

*With Thru-Drive Only

Thru-Drive Mounting Pad/Coupling	
0	No Thru-Drive
A	SAE 82-2(A), 16(A), 9T coupling
H	SAE 82-2(A), 19(--), 11T coupling

Paint	
00	No Paint
PB	Black Paint

Electronic Control Options	
#	#

0	No ECU
D	Proportional displacement control
Y	Proportional pressure and displacement control

P	Electronic valve with zero displacement default
T	Electronic valve with max displacement default
S	Electronic valve with zero displacement default and hydromechanical Pmax
U	Electronic valve with max displacement default and hydromechanical Pmax
W	Electronic valve with zero displacement default (CANBUS compatible)
X	Electronic valve with max displacement default (CANBUS compatible)
Y	Electronic valve with zero displacement default and hydromechanical Pmax (CANBUS compatible)
Z	Electronic valve with max displacement default and hydromechanical Pmax (CANBUS compatible)

*** W, X, Y and Z only available with "D*" and "Y*"

Piston Pumps

P1/PD 28cc, Model Ordering Code

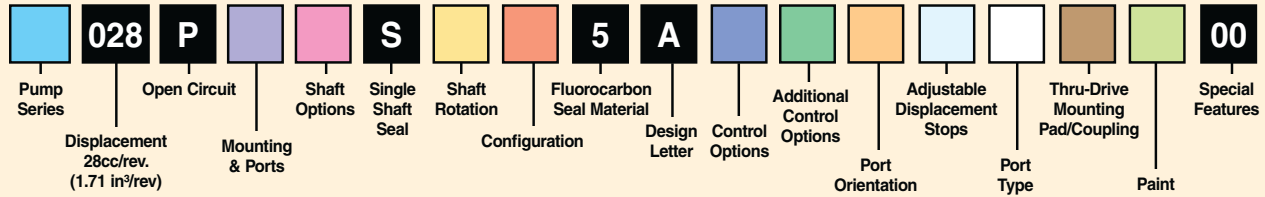

Pump Series	
P1	Mobile
PD	Industrial

Mounting & Ports	
S	SAE B Pilot SAE Work Ports with SAE Aux Ports
A	SAE B Pilot Metric Work Ports with BSPP Aux Ports
M	ISO - 100MM Pilot Metric Work Ports with Aux Ports
B	ISO - 100MM Pilot Metric Work Ports with BSPP Aux Ports

Shaft Options	
01	Splined shaft - SAE B-B 15T
02	Keyed shaft - SAE B-B 1" Dia.
04	ISO keyed 25MM Dia.
08	Splined shaft - SAE B 13T

Shaft Rotation	
R	Clockwise
L	Counterclockwise

Configuration	
M	Mobile (P1)
S	Industrial (PD)

Control Options	
C0	Pressure limiter 1160.30 - 4061.05 PSI (80 - 280 bar)
C1	Pressure limiter 290.08 - 1160.30 PSI (20 - 80 bar)
L0	Load sensing 145.04-435.11 PSI ΔP (10-30 bar ΔP) with pressure limiter 1160.30 - 4061.05 PSI (80 - 280 bar)
L2	Load sensing 145.04-435.11 PSI ΔP (10-30 bar ΔP) with bleed & pressure limiter 1160.30 - 4061.05 PSI (80 - 280 bar)
AN*	Pilot operated pressure limiter with ISO4401 interface & SAE 4 Vent Port
AM	Pilot operated pressure limiter with mechanical adjustment and SAE 4 Vent Port
AE	Pilot operated pressure limiter with mechanical and electrical adjustment 12 VDC
AF	Pilot operated pressure limiter with mechanical and electrical adjustment 24 VDC
##	See chart below for electronic control options

*Not functional control as such

Additional Control Options	
0	No other options
2	Displacement sensor **

** mandatory with "W***", "X***", "Y***", "Z***" "D*" and "Y*"

Port Orientation	
E	End Ports
R	Side ported with ripple chamber
T	Side ported with through drive

Adjustable Displacement Stops* (For E & R Port Orientation Only)	
0	None
1	Adjustable maximum displacement stop
2	Adjustable minimum displacement stop
3	Adjustable maximum and minimum displacement stop

*Not available with Thru-Drive

Port Type	
0	Flange Ports
2	Threaded Ports

Thru-Drive Mounting Pad/Coupling	
0	No Thru-Drive
A	SAE 82-2 (A), 16 (A), 9T coupling
H	SAE 82-2 (A), 19 (-), 11T coupling
B	SAE 101-2 (B), 22 (B) , 13T coupling
Q	SAE 101-2 (B), 25 (B-B), 15T coupling

Paint	
00	No Paint
PB	Black Paint

Electronic Control Options	
#	#

0	No ECU
D	Proportional displacement control
Y	Proportional pressure and displacement control

P	Electronic valve with zero displacement default
T	Electronic valve with max displacement default
S	Electronic valve with zero displacement default and hydromechanical Pmax
U	Electronic valve with max displacement default and hydromechanical Pmax
W	Electronic valve with zero displacement default (CANBUS compatible)
X	Electronic valve with max displacement default (CANBUS compatible)
Y	Electronic valve with zero displacement default and hydromechanical Pmax (CANBUS compatible)
Z	Electronic valve with max displacement default and hydromechanical Pmax (CANBUS compatible)

*** W, X, Y and Z only available with "D*" and "Y*"



Piston Pumps

P1/PD 45cc, Model Ordering Code

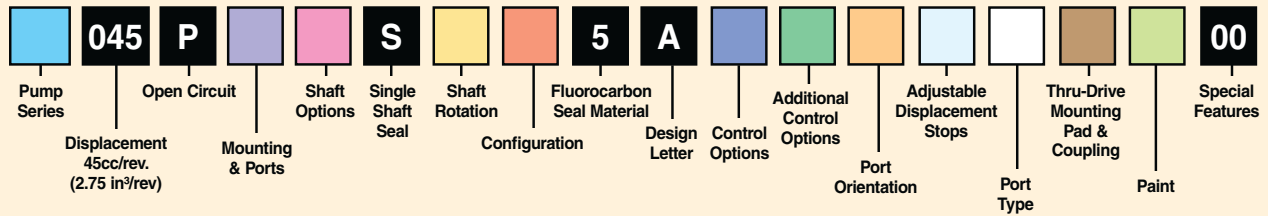

Pump Series	
P1	Mobile
PD	Industrial

Mounting & Ports	
S	SAE B Pilot with SAE Threaded or Flange Work Ports with SAE Aux Ports
A	SAE B Pilot with Metric Threaded or Metric Flange Work Ports with BSPP Aux Ports
M	ISO - 100MM Pilot Metric Threaded or Metric Flange Work Ports with Aux Ports
B	ISO - 100MM Pilot Metric Threaded or Metric Flange Work Ports with Aux Ports

Shaft Options	
01	Splined shaft - SAE B-B 15T
02	Keyed shaft - SAE B-B 1" Dia.
04	ISO keyed 25MM Dia.
08	Splined shaft - SAE B 13T

Shaft Rotation	
R	Clockwise
L	Counterclockwise

Configuration	
M	Mobile (P1)
S	Industrial (PD)
U	Universal (SAE Mounting Option, S, Only)

Control Options	
C0	Pressure limiter 1160.30 - 4061.05 PSI (80 - 280 bar)
C1	Pressure limiter 290.08 - 1160.30 PSI (20 - 80 bar)
L0	Load sensing 145.04-435.11 PSI ΔP (10-30 bar ΔP) with pressure limiter 1160.30 - 4061.05 PSI (80 - 280 bar)
L2	Load sensing 145.04-435.11 PSI ΔP (10-30 bar ΔP) with bleed & pressure limiter 1160.30 - 4061.05 PSI (80 - 280 bar)
AN*	Pilot operated pressure limiter with ISO4401 interface & SAE 4 Vent Port
AL	Pilot operated pressure limiter with Load sensing (only available with "T" Torque Limiter option, i.e. "ALT ")
AM	Pilot operated pressure limiter with mechanical adjustment and SAE 4 Vent Port
AE	Pilot operated pressure limiter with mechanical and electrical adjustment 12 VDC
AF	Pilot operated pressure limiter with mechanical and electrical adjustment 24 VDC
##	See chart below for electronic control options

*Not functional control as such

Additional Control Options	
0	No other options
2	Displacement sensor **
T	Torque Limiter Control (Used with AM, AN or AL control options)

** mandatory with "W***", "X***", "Y***", "Z***" "D*" and "Y*"

Port Orientation	
E	End Ports
R	Side ported with ripple chamber
T	Side ported with through drive

Adjustable Displacement Stops* (For E & R Port Orientation Only)	
0	None
1	Adjustable maximum displacement stop
2	Adjustable minimum displacement stop
3	Adjustable maximum and minimum displacement stop

*Not available with Thru-Drive

Port Type	
0	Flange Ports
2	Threaded Ports

Thru-Drive Mounting Pad/Coupling	
0	No Thru-Drive
A	SAE 82-2 (A), 16 (A), 9T coupling
H	SAE 82-2 (A), 19 (-), 11T coupling
B	SAE 101-2 (B), 22 (B), 13T coupling
Q	SAE 101-2 (B), 25 (B-B), 15T coupling

Paint	
00	No Paint
PB	Black Paint

Electronic Control Options

#	#
	0 No ECU
	D Proportional displacement control
	Y Proportional pressure and displacement control
P	Electronic valve with zero displacement default
T	Electronic valve with max displacement default
S	Electronic valve with zero displacement default and hydromechanical Pmax
U	Electronic valve with max displacement default and hydromechanical Pmax
W	Electronic valve with zero displacement default (CANBUS compatible)
Y	Electronic valve with max displacement default (CANBUS compatible)
X	Electronic valve with zero displacement default and hydromechanical Pmax (CANBUS compatible)
Z	Electronic valve with max displacement default and hydromechanical Pmax (CANBUS compatible)

*** W, X, Y and Z only available with "D*" and "Y*"

Piston Pumps

P1/PD 60cc, Model Ordering Code

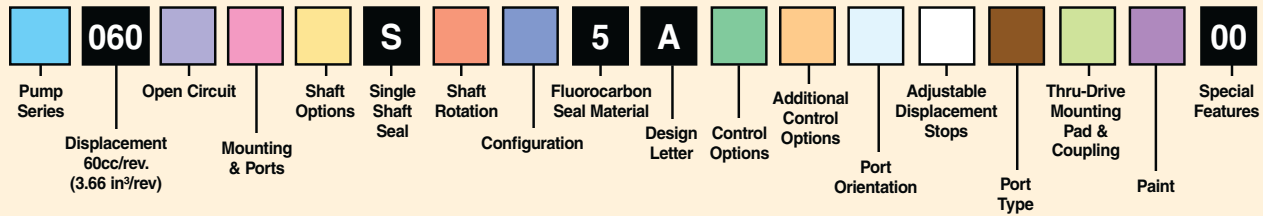

Pump Series	
P1	Mobile
PD	Industrial

Open Circuit	
P	Open Circuit (One Side of Center)
X	Open Circuit (100% over Center)

Mounting & Ports	
S	SAE C Pilot SAE Flange Connection Ports with SAE Aux Ports
A	SAE C Pilot Metric Flange Connection Ports with BSPP Aux Ports
M	ISO - 125MM Pilot Metric Flange Connection Ports with Metric Aux Ports
B	ISO - 125MM Pilot, Metric Flange Connection Ports with BSPP Aux Ports
C	SAE C 2-Bolt Pilot SAE Flange Connection Ports with SAE Aux Ports
D	SAE C 2-Bolt Pilot SAE Flange Connection Ports with BSPP Aux Ports

Shaft Options	
01	Spined shaft - SAE C 14T
02	Keyed shaft - SAE C 32-1 KEY
04	Keyed shaft - ISO / DIN KEY 32MM Dia.

Shaft Rotation	
R	Clockwise
L	Counterclockwise

Configuration	
M	Mobile (P1)
S	Industrial (PD)
U	Universal

Control Options	
C0	Pressure limiter 1160.30 - 4061.05 PSI (80 - 280 bar)
C1	Pressure limiter 290.08 - 1160.30 PSI (20 - 80 bar)
L0	Load sensing 145.04-435.11 PSI ΔP (10-30 bar ΔP) with pressure limiter 1160.30 - 4061.05 PSI (80 - 280 bar)
L2	Load sensing 145.04-435.11 PSI ΔP (10-30 bar ΔP) with bleed & pressure limiter 1160.30 - 4061.05 PSI (80 - 280 bar)
AN*	Pilot operated pressure limiter with ISO4401 interface & SAE 4 Vent Port
AL	Pilot operated pressure limiter with Load sensing (only available with "T" Torque Limiter option, i.e. "ALT ")
AM	Pilot operated pressure limiter with mechanical adjustment and SAE 4 Vent Port
AE	Pilot operated pressure limiter with mechanical and electrical adjustment 12 VDC
AF	Pilot operated pressure limiter with mechanical and electrical adjustment 24 VDC
##	See chart below for electronic control options

*Not functional control as such

Additional Control Options	
0	No other options
2	Displacement sensor **
T	Torque Limiter Control (Used with AM, AN or AL control options)

** mandatory with "W***", "X***", "Y***", "Z***" "D" and "Y"

Port Orientation	
E	End Ports
S	Side Ports
T	Side Ports with Thru-Drive

Adjustable Displacement Stops* (For E & S Port Orientation Only)	
0	None
1	Adjustable maximum displacement stop
2	Adjustable minimum displacement stop
3	Adjustable maximum and minimum displacement stop

*Not available with Thru-Drive

Port Type	
0	Flange Ports
2	SAE Threaded Ports (Available only on "E" port and "S" or "C" mount)
4	BSPP Threaded Ports (Available only on "E" port and "D" mount)

Thru-Drive Mounting Pad/Coupling	
0	No Thru-Drive
A	SAE 82-2 (A), 16 (A), 9T coupling
H	SAE 82-2 (A), 19 (-), 11T coupling
B	SAE 101-2 (B), 22 (B), 13T coupling
Q	SAE 101-2 (B), 25 (B-B), 15T coupling
J	SAE 101-2 (B), rotated 45 degrees, 22 (B), 13T coupling
K	SAE 101-2 (B), rotated 45 degrees, 25 (B-B), 15T coupling
C	SAE 127-4 (C), 32 (C), 14T coupling

Paint	
00	No Paint
PB	Black Paint

Electronic Control Options	
#	#

0	No ECU
D	Proportional displacement control
Y	Proportional pressure control

P	Electronic valve with zero displacement default
T	Electronic valve with max displacement default
S	Electronic valve with zero displacement default and hydromechanical Pmax
U	Electronic valve with max displacement default and hydromechanical Pmax
W	Electronic valve with zero displacement default (CANBUS compatible)
Y	Electronic valve with max displacement default (CANBUS compatible)
X	Electronic valve with zero displacement default and hydromechanical Pmax (CANBUS compatible)
Z	Electronic valve with max displacement default and hydromechanical Pmax (CANBUS compatible)

*** W, X, Y and Z only available with "D" and "Y"



Piston Pumps

P1/PD 75cc, Model Ordering Code

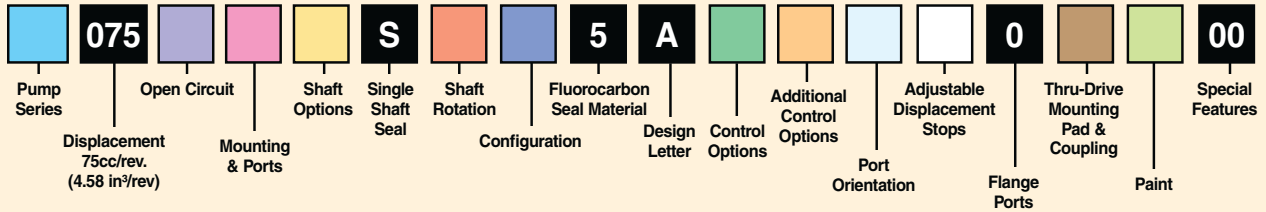

Pump Series	
P1	Mobile
PD	Industrial

Open Circuit	
P	Open Circuit (One Side of Center)
X	Open Circuit (100% over Center)

Mounting & Ports	
S	SAE C Pilot SAE Flange Connection Ports with SAE Aux Ports
A	SAE C Pilot Metric Flange Connection Ports with BSPP Aux Ports
M	ISO - 125MM Pilot Metric Flange Connection Ports with Metric Aux Ports
B	ISO - 125MM Pilot, Metric Flange Connection Ports with BSPP Aux Ports
C	SAE C 2-Bolt Pilot SAE Flange Connection Ports with SAE Aux Ports
D	SAE C 2-Bolt Pilot SAE Flange Connection Ports with BSPP Aux Ports

Shaft Options	
01	Spined shaft - SAE C 14T
02	Keyed shaft - SAE C 32-1 KEY
04	Keyed shaft - ISO / DIN KEY 32MM Dia.

Shaft Rotation	
R	Clockwise
L	Counterclockwise

Configuration	
M	Mobile (P1)
S	Industrial (PD)
U	Universal

Control Options	
C0	Pressure limiter 1160.30 - 4061.05 PSI (80 - 280 bar)
C1	Pressure limiter 290.08 - 1160.30 PSI (20 - 80 bar)
L0	Load sensing 145.04-435.11 PSI ΔP (10-30 bar ΔP) with pressure limiter 1160.30 - 4061.05 PSI (80 - 280 bar)
L2	Load sensing 145.04-435.11 PSI ΔP (10-30 bar ΔP) with bleed & pressure limiter 1160.30 - 4061.05 PSI (80 - 280 bar)
AN*	Pilot operated pressure limiter with ISO4401 interface & SAE 4 Vent Port
AM	Pilot operated pressure limiter with mechanical adjustment and SAE 4 Vent Port
AE	Pilot operated pressure limiter with mechanical and electrical adjustment 12 VDC
AF	Pilot operated pressure limiter with mechanical and electrical adjustment 24 VDC
##	See chart below for electronic control options

*Not functional control as such

Additional Control Options	
0	No other options
2	Displacement sensor **
T	Torque Limiter Control (Used with AM, AN or L0 control options)

** mandatory with "W***", "X***", "Y***", "Z***" "D*" and "Y"

Port Orientation	
E	End Ports
S	Side Ports
T	Side Ports with Thru-Drive

Adjustable Displacement Stops* (For E & S Port Orientation Only)	
0	None
1	Adjustable maximum displacement stop
2	Adjustable minimum displacement stop
3	Adjustable maximum and minimum displacement stop

*Not available with Thru-Drive

Thru-Drive Mounting Pad/Coupling	
0	No Thru-Drive
A	SAE 82-2 (A), 16 (A), 9T coupling
H	SAE 82-2 (A), 19 (--), 11T coupling
B	SAE 101-2 (B), 22 (B), 13T coupling
Q	SAE 101-2 (B), 25 (B-B), 15T coupling
J	SAE 101-2 (B), rotated 45 degrees, 22 (B), 13T coupling
K	SAE 101-2 (B), rotated 45 degrees, 25 (B-B), 15T coupling
C	SAE 127-4 (C), 32 (C), 14T coupling

Paint	
00	No Paint
PB	Black Paint

Electronic Control Options	
#	#

0	No ECU
D	Proportional displacement control
Y	Proportional pressure control

P	Electronic valve with zero displacement default
T	Electronic valve with max displacement default
S	Electronic valve with zero displacement default and hydromechanical Pmax
U	Electronic valve with max displacement default and hydromechanical Pmax
W	Electronic valve with zero displacement default (CANBUS compatible)
Y	Electronic valve with max displacement default (CANBUS compatible)
X	Electronic valve with zero displacement default and hydromechanical Pmax (CANBUS compatible)
Z	Electronic valve with max displacement default and hydromechanical Pmax (CANBUS compatible)

*** W, X, Y and Z only available with "D*" and "Y"

Piston Pumps

P1/PD 100cc, Model Ordering Code

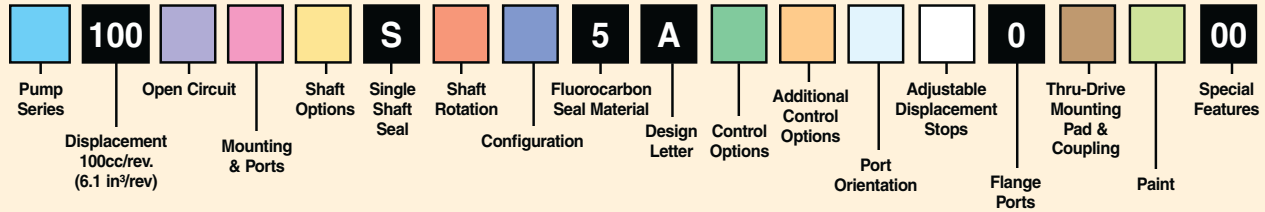

Pump Series	
P1	Mobile
PD	Industrial

Open Circuit	
P	Open Circuit (One Side of Center)
X	Open Circuit (100% over Center)

Mounting & Ports	
S	SAE C Pilot SAE Flange Connection Ports with SAE Aux Ports
A	SAE C Pilot Metric Flange Connection Ports with BSPP Aux Ports
M	ISO - 125MM Pilot Metric Flange Connection Ports with Metric Aux Ports
B	ISO - 125MM Pilot, Metric Flange Connection Ports with BSPP Aux Ports

Shaft Options	
01	Splined shaft - SAE C-C 17T
02	Keyed shaft - SAE C-C 38-1
04	Keyed shaft - ISO / DIN 40MM Dia.
06	Splined shaft - SAE C 14T

Shaft Rotation	
R	Clockwise
L	Counterclockwise

Configuration	
M	Mobile (P1)
S	Industrial (PD)
U	Universal

Control Options	
C0	Pressure limiter 1160.30 - 4061.05 PSI (80 - 280 bar)
C1	Pressure limiter 290.08 - 1160.30 PSI (20 - 80 bar)
L0	Load sensing 145.04-435.11 PSI ΔP (10-30 bar ΔP) with pressure limiter 1160.30 - 4061.05 PSI (80 - 280 bar)
L2	Load sensing 145.04-435.11 PSI ΔP (10-30 bar ΔP) with bleed & pressure limiter 1160.30 - 4061.05 PSI (80 - 280 bar)
AN*	Pilot operated pressure limiter with ISO4401 interface & SAE 4 Vent Port
AM	Pilot operated pressure limiter with mechanical adjustment and SAE 4 Vent Port
AE	Pilot operated pressure limiter with mechanical and electrical adjustment 12 VDC
AF	Pilot operated pressure limiter with mechanical and electrical adjustment 24 VDC
##	See chart below for electronic control options

*Not functional control as such

Additional Control Options	
0	No other options
2	Displacement sensor **
T	Torque Limiter Control (Used with AM, AN or L0 control options)

** mandatory with "W***", "X***", "Y***", "Z***" "D*" and "Y"

Port Orientation	
E	End Ports
S	Side Ports
T	Side Ports with Thru-Drive

Adjustable Displacement Stops* (For E & S Port Orientation Only)	
0	None
1	Adjustable maximum displacement stop
2	Adjustable minimum displacement stop
3	Adjustable maximum and minimum displacement stop

*Not available with Thru-Drive

Thru-Drive Mounting Pad/Coupling	
0	No Thru-Drive
A	SAE 82-2 (A), 16 (A), 9T coupling
H	SAE 82-2 (A), 19 (-), 11T coupling
B	SAE 101-2 (B), 22 (B), 13T coupling
Q	SAE 101-2 (B), 25 (B-B), 15T coupling
J	SAE 101-2 (B), rotated 45 degrees, 22 (B), 13T coupling
K	SAE 101-2 (B), rotated 45 degrees, 25 (B-B), 15T coupling
C	SAE 127-4 (C), 32 (C), 14T coupling
N	SAE 127-4 (C), 38 (C-C), 17T coupling

Paint	
00	No Paint
PB	Black Paint

Electronic Control Options	
#	#

0	No ECU
D	Proportional displacement control
Y	Proportional pressure control

P	Electronic valve with zero displacement default
T	Electronic valve with max displacement default
S	Electronic valve with zero displacement default and hydromechanical Pmax
U	Electronic valve with max displacement default and hydromechanical Pmax
W	Electronic valve with zero displacement default (CANBUS compatible)
Y	Electronic valve with max displacement default (CANBUS compatible)
X	Electronic valve with zero displacement default and hydromechanical Pmax (CANBUS compatible)
Z	Electronic valve with max displacement default and hydromechanical Pmax (CANBUS compatible)

*** W, X, Y and Z only available with "D*" and "Y"



Piston Pumps

P1/PD 140cc, Model Ordering Code

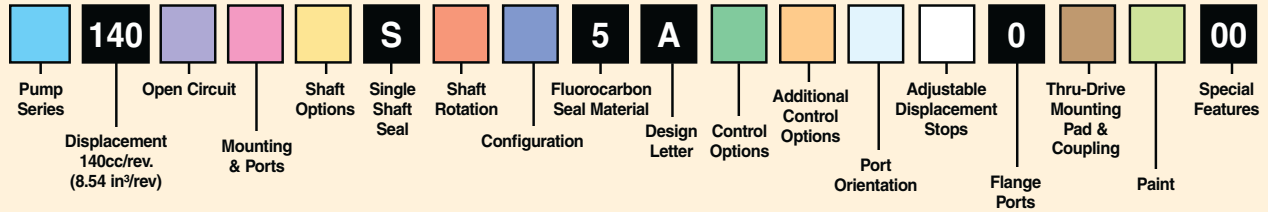

Pump Series	
P1	Mobile
PD	Industrial

Open Circuit	
P	Open Circuit (One Side of Center)
X	Open Circuit (100% over Center)

Mounting & Ports	
S	SAE D Pilot SAE Flange Connection Ports with SAE Aux Ports
A	SAE D Pilot BSPP Flange Connection Ports with BSPP Aux Ports
M	ISO - 180MM Pilot Metric Flange Connection Ports with Metric Aux Ports
B	ISO - 180MM Pilot Metric Flange Connection Ports with BSPP Aux Ports

Shaft Options	
01	Spined shaft - SAE D 13T
02	Keyed shaft - SAE D 44-1
04	Keyed shaft - ISO / DIN 50MM Dia.

Shaft Rotation	
R	Clockwise
L	Counterclockwise

Configuration	
M	Mobile (P1)
S	Industrial (PD)
U	Universal

Control Options	
C0	Pressure limiter 1160.30 - 4061.05 PSI (80 - 280 bar)
C1	Pressure limiter 290.08 - 1160.30 PSI (20 - 80 bar)
L0	Load sensing 145.04-435.11 PSI ΔP (10-30 bar ΔP) with pressure limiter 1160.30 - 4061.05 PSI (80 - 280 bar)
L2	Load sensing 145.04-435.11 PSI ΔP (10-30 bar ΔP) with bleed & pressure limiter 1160.30 - 4061.05 PSI (80 - 280 bar)
AN*	Pilot operated pressure limiter with ISO4401 interface & SAE 4 Vent Port
AM	Pilot operated pressure limiter with mechanical adjustment and SAE 4 Vent Port
AE	Pilot operated pressure limiter with mechanical and electrical adjustment 12 VDC
AF	Pilot operated pressure limiter with mechanical and electrical adjustment 24 VDC
##	See chart below for electronic control options

*Not functional control as such

Additional Control Options	
0	No other options
2	Displacement sensor **
T	Torque Limiter Control (Used with AM, AN or L0 control options)

** mandatory with "W***", "X***", "Y***", "Z***" "D" and "Y"

Port Orientation	
E	End Ports
S	Side Ports
T	Side Ports with Thru-Drive

Adjustable Displacement Stops* (For E & S Port Orientation Only)	
0	None
1	Adjustable maximum displacement stop
2	Adjustable minimum displacement stop
3	Adjustable maximum and minimum displacement stop

*Not available with Thru-Drive

Thru-Drive Mounting Pad/Coupling	
0	No Thru-Drive
A	SAE 82-2 (A), 16 (A), 9T coupling
B	SAE 101-2 (B), 22 (B), 11T coupling
Q	SAE 101-2 (B), 25 (B-B), 13T coupling
J	SAE 101-2 (B), rotated 45 degrees, 22 (B), 15T coupling
K	SAE 101-2 (B), rotated 45 degrees, 25 (B-B), 13T coupling
C	SAE 127-4 (C), 32 (C), 14T coupling
N	SAE 127-4 (C), 38 (C-C), 17T coupling
D	SAE 152-4 (D), 44 (D), 13T coupling

Paint	
00	No Paint
PB	Black Paint

Electronic Control Options	
#	#

0	No ECU
D	Proportional displacement control
Y	Proportional pressure control

P	Electronic valve with zero displacement default
T	Electronic valve with max displacement default
S	Electronic valve with zero displacement default and hydromechanical Pmax
U	Electronic valve with max displacement default and hydromechanical Pmax
W	Electronic valve with zero displacement default (CANBUS compatible)
Y	Electronic valve with max displacement default (CANBUS compatible)
X	Electronic valve with zero displacement default and hydromechanical Pmax (CANBUS compatible)
Z	Electronic valve with max displacement default and hydromechanical Pmax (CANBUS compatible)

*** W, X, Y and Z only available with "D" and "Y"